

PQ1 CZ1

Surface Mount Type Chopper Regulator

■ Features

- Surface mount type package (equivalent to SC-63, 5-terminal type)
- Variable output voltage (1.26V to 35V/ -1.26V to -30V)
- Built-in ON/OFF control function
- Built-in overheat protection function and overcurrent protection function

■ Applications

- Personal computers
- Word processors
- Printers
- Car audio equipment

■ Outline Dimensions

(Unit :mm)

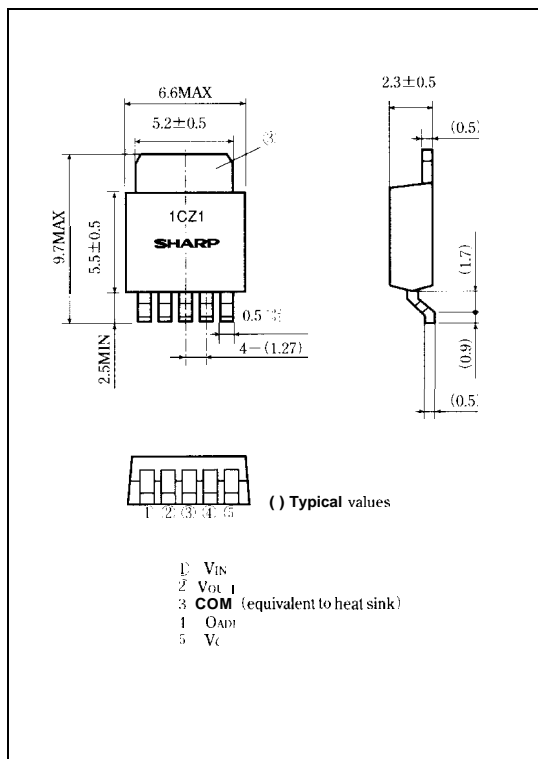

■ Absolute Maximum Ratings

(Ta=25°C)

Input-output voltage	V _{I-O}	41	V
Switching current	I _{SW}	1.5	A
*2 Voltage between output and COM	V _{OUT}	-1	V
*3 ON/OFF control voltage	V _C	-0.3 to 3.0	V
*4 Power dissipation	P _D	8	W
Junction temperature	T _J	150	°C
Operating temperature	T _{opr}	-20 to +80	°C
Storage temperature	T _{stg}	-40 to +150	°C
Soldering temperature	T _{sol}	260 (For 10s)	°C

*1 Voltage between V_{IN} terminal and COM terminal.*2 Voltage between V_{OUT} terminal and COM terminal.*3 Voltage between V_C terminal and COM terminal.

*4 With infinite heat sink, Refer to Fig.1

Please refer to the chapter "Handling Precautions"

SHARP

Electrical Characteristics (Unless otherwise specified, condition shall be $V_{IN}=12V, I_o=0.2A, V_{out}=5V$, ⑤ terminal is open, $T_a=25^\circ C$)

Parameter	Symbol	Conditions	MIN.	TYP.	MAX.	Unit
Output saturation voltage	V_{SAI}	$I_o = 1A$, no L,D,C _o		0.9	1.5	v
Reference voltage	V_{ref}		1.235	1.26	1.285	v
Temperature fluctuation in reference voltage	ΔV_{ref}	$T_a = 0$ to $125^\circ C$		± 0.5		%
Load regulation	R_{egL}	$I_o = 0.2$ to $1A$		0.1	1.5	%
Line regulation	R_{egI}	$V_{IN} = 8$ to $35V$		0.5	2.5	%
Efficiency	η	$I_o = 1A$		82		%
Oscillation frequency	f_o		80	100	120	kHz
Oscillation frequency temperature fluctuation	Δf_o	$T_j = 0$ to $125^\circ C$		± 2		%
Maximum duty	D_{MAX}	④ terminal = open	90			%
Overcurrent detecting level	I_L	No L,D,C _o	1.55	2	2.6	A
Charge current	I_{CHG}	②,④ terminals are open	-15	-10	-5	μA
Input threshold voltage	V_{THL}	Duty=0%, ④ terminal=OV, ⑤ terminal	1.95	2.25	2.55	v
	V_{THH}	Duty= D_{MAX} , ④ terminal is open, ⑤ terminal	3.25	3.55	3.85	
ON threshold voltage	V_{THON}	⑤ terminal	1.05	1.4	1.75	v
Stand-by current	$ I_{st} $	$V_{IN} = 40V$, ⑤ terminal =OV		150	400	μA
Output OFF-state consumption current	I_{qs}	$V_{IN} = 40V$, ④ terminal =3V		8	12	mA

Test Circuit

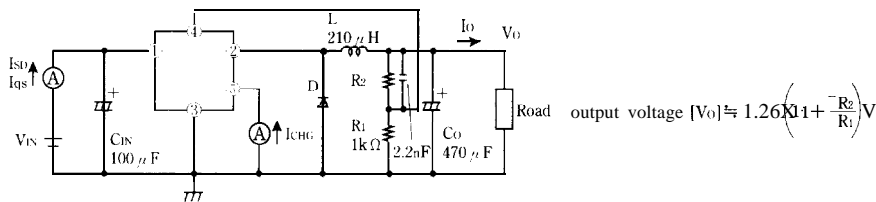

L: HK-HK14D10W2110 (made by Toho Co.)
 D: ERC80-004 (made by Fuji electronics Co.)

Fig.1 Power Dissipation vs. Ambient Temperature

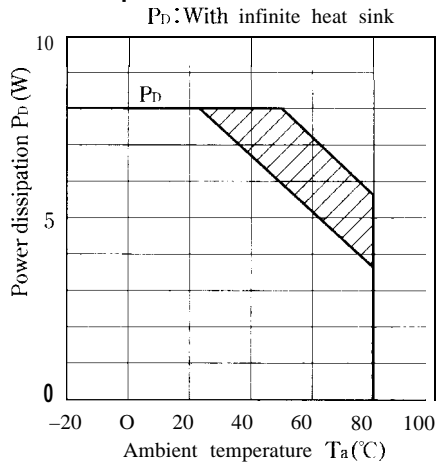

Note) Oblique line portion : Overheat protection may operate in this area.

Fig.2 Power Dissipation vs. Ambient Temperature (Typical Value)

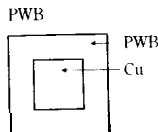
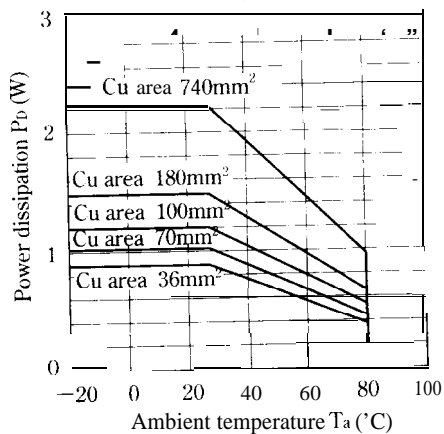

Material : Glass clothepoxyresin
 Size : 50X50X1.6mm
 Cu thickness : 35 μm

Fig.3 Efficiency vs. Input Voltage

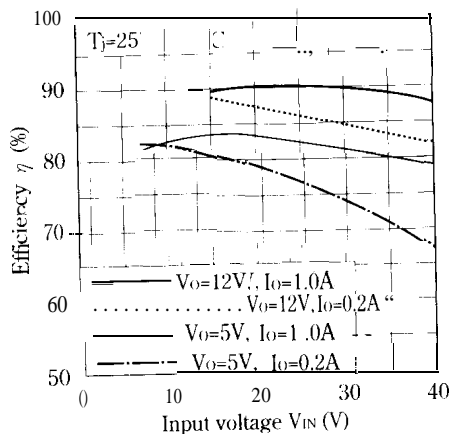

Fig.4 Switching Current vs. Output Saturation Voltage

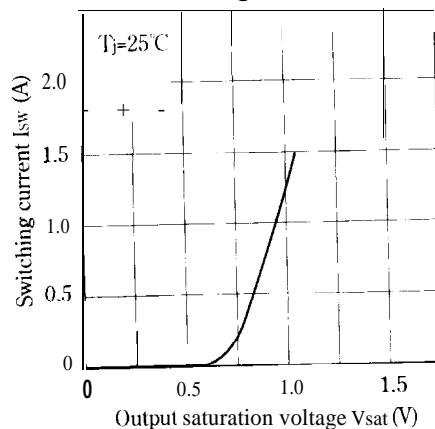

Fig.5 Stand-by Current vs. Input Voltage

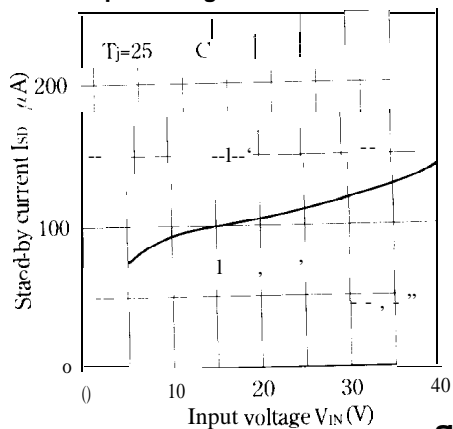
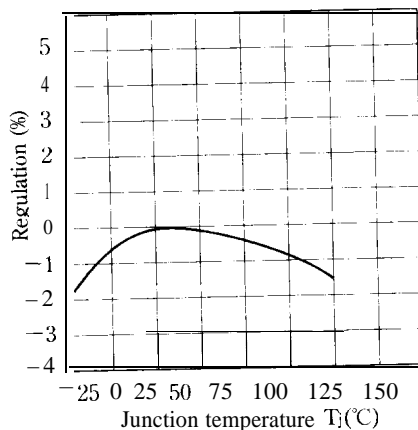
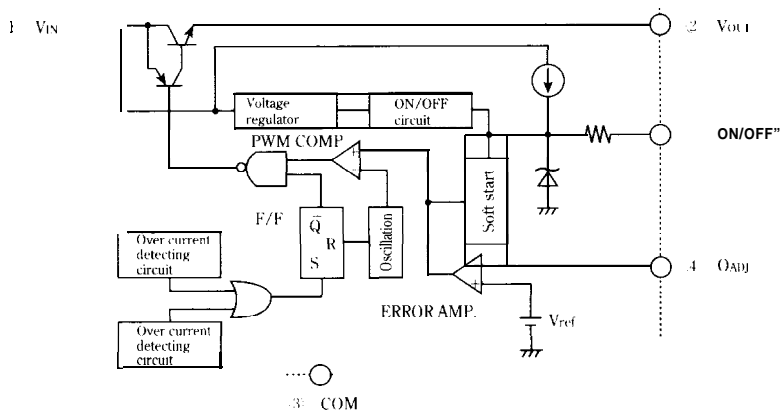

Fig.6 Regulation vs. Junction Temperature



Block Diagram



Step Down Type Circuit Diagram (5V output)

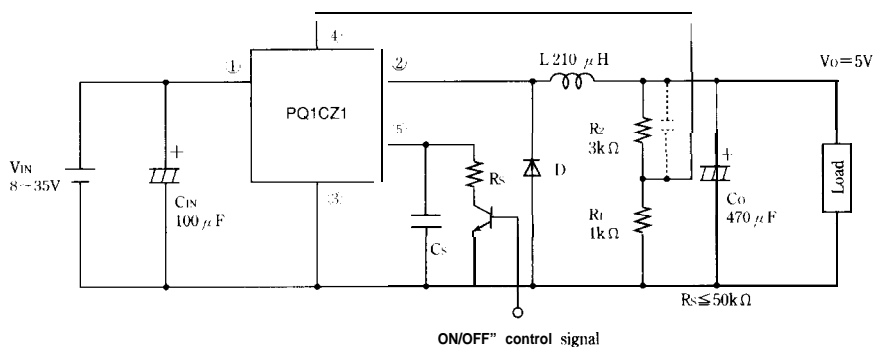

Polarity Inversion Type Circuit Diagram (-5V output)

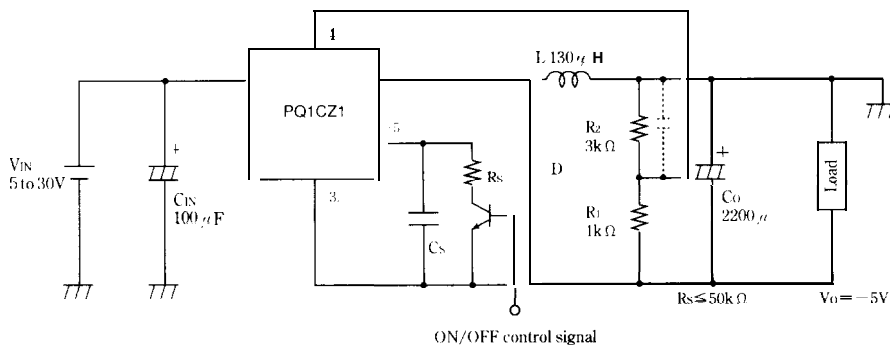

External Connection

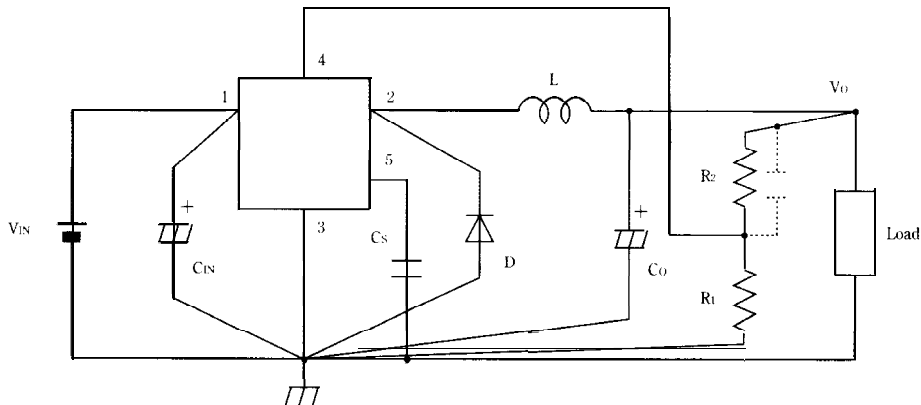

- ① Wiring condition is very important, Noise associated with wiring inductance may cause problems, For minimizing inductance, it is recommended to design the thick and short pattern (between large current diodos, input/output capacitors, and terminal 1,2.) Single-point grounding (as indicated) should be used for best results.
- ② When output voltage is not stable, it can be improved by attaching capacitor (from several nF to several dozens nF) to external resistor R_z.
- ③ High switching speed and low forward voltage type schottky barrier diode should be recommended for the catch-diode D because it affectsthe efficiency, Please select the diode which the current rating is at least 1.2 times greater than maximum swiching current.
- ④ The output ripple voltage is highly influenced by ESR (Equivalent Series Resistor) of output capacitor, and can be minimized by selecting Low ESR capacitor.
- ⑤ An inductor should not be operated beyond its maximum rated current so that it may not saturate.

Thermal Protection Design

Internal power dissipation (P)of device is generally obtained by the following equation.

$$P = I_{sw} \text{ (Average,)} \times V_{SAT} \times D' + V_{IN} \text{ (voltage between } V_{IN} \text{ to COM terminal)} \times I_q' \text{ (consumption current)}$$

Step down type

$$D' \text{ (Duty)} = \frac{T_{on}}{T \text{ (period)}} = \frac{V_O + V_F}{V_{IN} - V_{SAT} + V_F}$$

$$I_{sw} \text{ (Average)} = I_O \text{ (Output current.)}$$

Polarity inversion type

$$D' \text{ (Duty)} = \frac{T_{<}}{T \text{ (period)}} = \frac{V_O + V_i}{V_{IN} + V_O - V_{SAT} + V_F}$$

$$I_{sw} \text{ (Average)} = \frac{1}{1-D'} \times I_O \text{ (Output current.)}$$

V_F: Forward **voltage** of the diode

When ambient temperature Ta and power dissipationP_D (MAX) during operation are determined, use Cu plate which allows the element to operate within the safety operation area specified by the derating curve, Insufficient radiation gives an unfavorable influence to the normal operation and reliability of the device.

In the external area of the safety operation area shown by the derating curve, the overheat protection circuit may operate to shut-down output. However, please avoid keeping such condition for a long time.

■ ON/OFF Control Terminal

In the following circuit, when ON/OFF control terminal ⑤ becomes low by switching transistor Tr on, output voltage may be turned OFF and the device becomes stand-by mode. Dissipation current at stand-by mode becomes Max.400 μ A.

(soft start)

When capacitor Cs is attached, output pulse gradually expanded and output voltage will start softly.

(ON/OFF control with soft startup)

For ON/OFF control with capacitor Cs, be careful not to destroy a transistor Tr by discharge current from Cs, adding a resistor restricting discharge current of Cs.

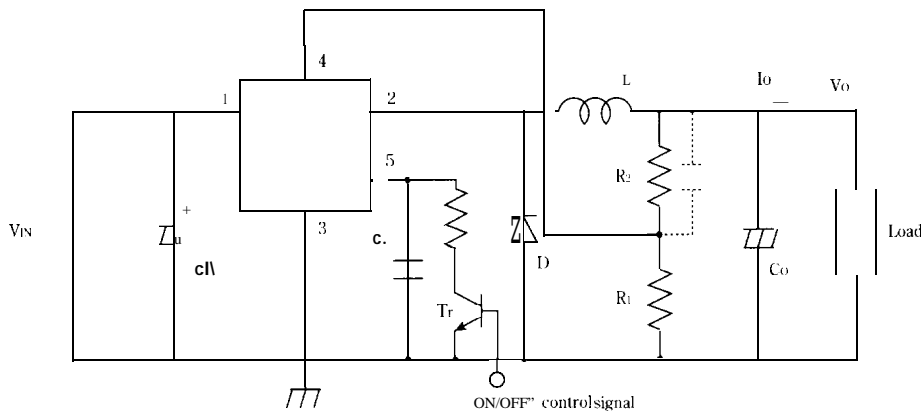

Step Down Voltage Circuit

